

SMD LAN Inductor for Capacitive Type LAN Module

DCM3532F2SF-750T03

1. Features

1. High common mode impedance at high frequency effects excellent noise suppression performance.
2. DCM3532F2SF series realizes small size and low profile. 3.5x3.2x2.3mm
3. 100% Lead(Pb) & Halogen-Free and RoHS compliant.
4. Operating temperature-40~+85°C (Including self - temperature rise)



2. Dimension

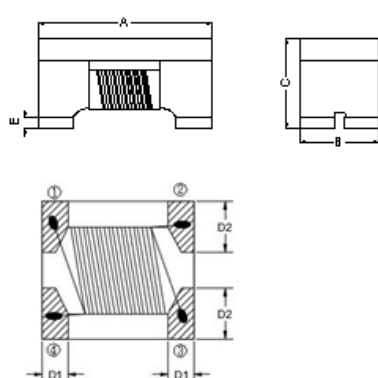

Recommended PC Board Pattern

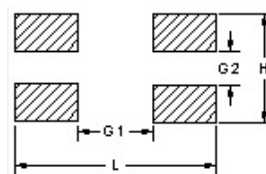

Series	A(mm)	B(mm)	C(mm)	D1(mm)	D2(mm)	L(mm)	H(mm)	G1(mm)	G2(mm)
3532F2SF	3.5±0.2	3.2±0.2	2.3±0.2	0.63±0.1	1.18±0.1	4.40	3.80	2.45	0.90

Units: mm

3. Part Numbering

DCM 3532 F 2 S F - 750 - T03

A B C D E F G H

A: Series
 B: Dimension
 C: Material Ferrite Core
 D: Number of Lines 2=2 lines
 E: Type S=Shielded
 F: Lead free
 G: Inductance 750=75 μ H
 H: Rated Current 03=300mA

4. Specification

TAI-TECH Part Number	Inductance(μ H) [100kHz/0.1V] Min.	DC Resistance (Ω)Max.	Rated Current (mA)	Rated Volt. (Vdc)	Withstand Volt. (Vdc) max.	IR(Ω) min.
DCM3532F2SF-750T03	75	0.8	300	50	125	10M

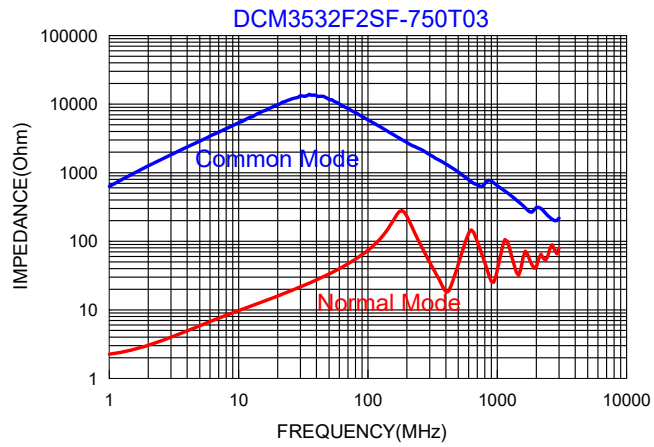

5. MEASURING CIRCUITS 2LINE

Common mode

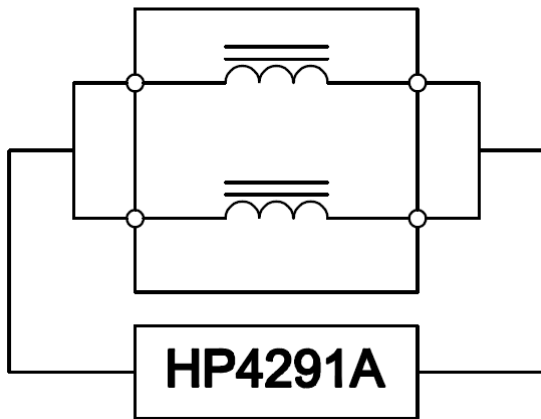

Differential mode

